

MME 36

36 kV
630 - 1250 A
16 - 20 kA

**MEDIUM VOLTAGE SWITCHGEAR
WITH SF6 LBS
METAL ENCLOSED (LSC2A)**



according to



3B Energy can propose a huge number of Products related to Energy sector. We are active in the whole world of Power Transmission and Distribution. Medium Voltage switchgears, Medium Voltage switches, Low Voltage PC, Low Voltage MCCs with fix and withdrawable units, Transformers, Cabinets; 3B Energy can propose a wide range of Products for fulfilling any request and need.

3B Energy is very active and smart in assisting customers for finding Solutions related to Energy sector. We can support the customer during engineering phase of the plant, during purchasing steps, for the supply and after-sales services. 3B Energy is a real “turnkey” Solution provider; Package Substations, Transformer Substations, Mobile Cabinets; we can propose a complete solution set for letting the customer have one player only for his whole plant.

3B Energy can propose a complete and detailed list of Services which can cover each step of Engineering phase. Our technical staff is highly expert and professional and can support the customer starting from the base design of a single component till a complete apparatus for electrical application. We can design and project every component the customer may need: a single contact or a complete switching device, we can develop and engineer the technology for any product or application of Energy sector



MME 36

36 kV
630 - 1250 A
16 - 20 kA

Contents

Description 4

Unit Types 6

Technical Data 7

Series 8

MS 17

Components 18

GENERAL

- ✓ MME series Metal Enclosed units which are produced by our company, have been designed and tested to be used for all energy distribution systems till 36 kV
- ✓ Modular Metal Enclosed units appear as the optimal solution with their easiness of taking operation by means of their modular structure and with their module apposition characteristic for companies
- ✓ MME series Metal enclosed unit are manufactured according to IEC Standards
- ✓ Optimal dimensions
- ✓ Long term technical solutions for various applications
- ✓ High level personal safety

APPLICATIONS

- ✓ Manufacturing industry
- ✓ Secondary electricy distribution networks
- ✓ Shopping malls
- ✓ MV / LV distribution transformer substations
- ✓ Small size power plants
- ✓ Wind power plants
- ✓ Airports, hospitals, holiday village

**Enclosure of cubicle is 2 mm galvanized steel sheet. If desired al-zinc is also possible.
No welding during the assembling of the structure.**

SAFETY

- ✓ There is a surveillance window on the front cover of the every cubicle to check inside the cubicle without open the door / cover
- ✓ The door / cover of the accessible compartments is mechanically interlocked with the earthing switches
- ✓ High voltage indication system in each cubicle

STANDARDS

- ✓ Compliance with standards IEC 62271 - 200
Classification; (according to IEC 62271 - 200)
- ✓ Classification of service contunity: LSC 2A
- ✓ Classification of the partitions: (Partition: Insulated or Metallic)
- ✓ Classification of arc proofing: IAC A (FL), IAC A (FLR)

1

Busbar compartment

is located on the top of the cubicle. It contains the main busbar which interconnect between cubicles. And also:

- ✓ Tool based accessible compartment with regard to accessibility, (it means that is not possible to open the covers without using any tools)
- ✓ Withstand to internal arc
- ✓ Having IP 3X protection degree

2

Cable compartment

compartment Cable compartment is located at the bottom of the cubicle. It contains switching devices, measuring transformers., HV fuses, earthing devices, support insulators according to the functional type of the cubicle. Incoming / outgoing MV cable connection of the cubicle is made in this compartment. The door has an inspection window. And also:

- ✓ Procedure based accessible compartment with regard to accessibility, (it means that it is possible to open the covers without using any tools)
- ✓ Withstand to internal arc
- ✓ IP 3X protection degree

3

Low voltage compartment

Low voltage compartment is located on the front - top of the cubicle having IP3X protection degree. According to the functional type of the cubicle, it contains, protection relays, LV fuses, measurment instruments, auxilary relays, miniature circuit breakers, terminal arrays, AC/DC supply, etc.

4

Operating mechanism compartment

Operating mechanism compartment is located on the front of the cubicle. According to the functional type of the cubicle it contains; load-break switch mechanism, earthing switch mechanism and same interlocking metal parts.

Circuit breakers has own mechanism, separately.

All metal parts of the operating mechanism are protected agains to corrosion

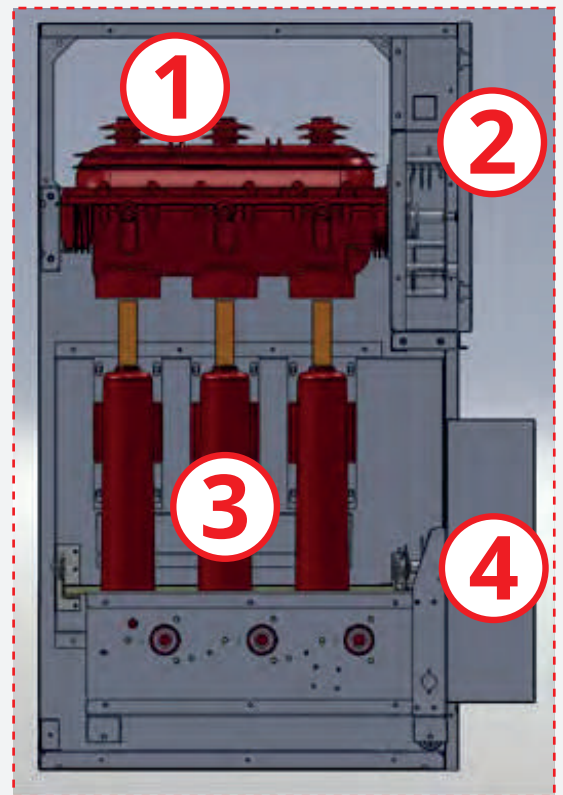

Type MME 361
Incoming Cable Unit

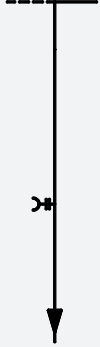

Type MME 362
Incoming Cable with Earthing Unit

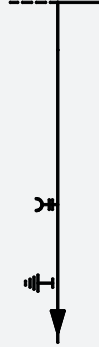

Type MME 363
Line with Metering Unit

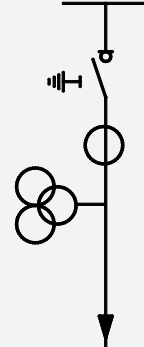

Type MME 364
Metering Unit

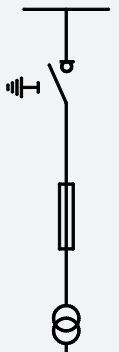

Type MME 365
Bus Riser with Metering Unit

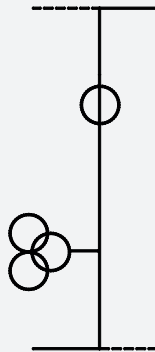

Type MME 366
Bus Riser Unit

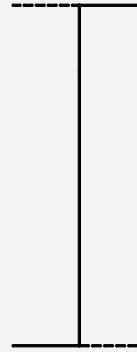

Type MME 367
Line Switch Unit



Type MME 368
Transformer Protection Unit

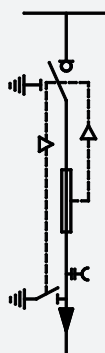

Type MME 369
Circuit-Breaker Unit

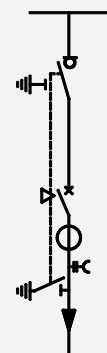

Rated voltage	kV	36
Rated lightning impulse withstand voltage	kV peak	
- Across phases and phase to neutral		170
- Across the isolating distance		195
Rated power frequency withstand voltage	kV eff	
- Across phases and phase to neutral		70
- Across the isolating distance		82
Rated frequency	Hz	50 / 60
Rated current		
- Busbar		630 / 1250
- Feeder / branch		630 / 1250
Rated short time withstand current	kA eff	
- Main circuit		20
- Earthing circuit		20
Rated peak withstand current	kA peak	50
Rated duration of short circuit	s	1
Arc fault current, 1 s	kA	16
Internal arc class		A(FLR)/A(FL)
Partitions class		PI
Loss of the service continuity		LSC2A
Degree of protection, enclosure		IP3X
Degree of protection, partitions		IP3X
Ambient temperature	° C	
- Maximum value		+40
- Maximum value of 24 h mean		+35
- Minimum value		-5
Altitude above sea level	m	≤1000

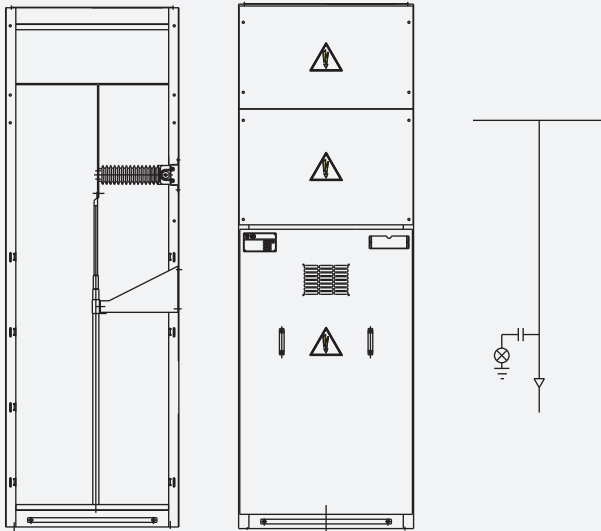

Standard equipment

- 1.Voltage indicator device
- 2.Busbars
- 3.Earthing bar
- 4.Heater
- 5.Interlocking unit

Technical data

Rated voltage	[kV]	36
Rated current	[A]	630/1250
Rated short-time withstand current	[kA]	20
Maximum rated duration of short circuit	[s]	1
Net Weight	kg	210
Width	mm	700
Depth	mm	1400
Height	mm	2250

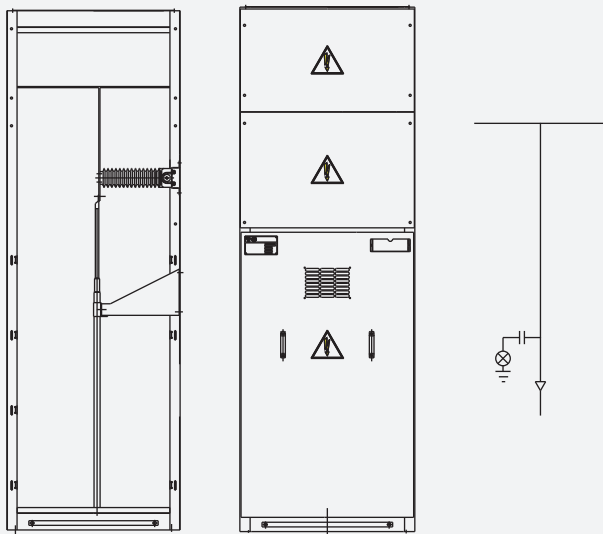

Standard equipment

1. Earthing switch
2. Voltage indicator device
3. Busbars
4. Earthing bar
5. Heater
6. Interlocking unit

Technical data

Rated voltage	[kV]	36
Rated current	[A]	630/1250
Rated short-time withstand current	[kA]	20
Maximum rated duration of short circuit	[s]	1
Net Weight	kg	210
Width	mm	700
Depth	mm	1400
Height	mm	2250

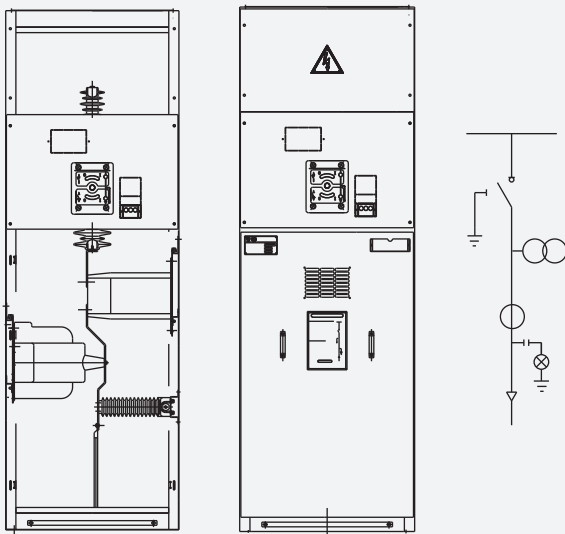

Standard equipment

1. 3 Position SF6 load break switch (open - closed - earthed)
2. Operating mechanism with mechanical position indication
3. Current and Voltage transformers
4. Voltage indicator device
5. Heater
6. Earthing bar
7. Busbars
8. Interlocking unit
9. Auxiliary contacts for close (2NO+2NC) and earth (2NO+2NC) position
10. Cable entry with cable support

Optional equipments

1. Gas density indication
2. Gas density indication with alarm contact
3. Motor operation device
4. Surge arresters
5. Cable fault indication device
6. Arc-gas channelline

Technical data

Rated voltage	[kV]	36
Rated current	[A]	630/1250
Rated short-time withstand current	[kA]	20
Maximum rated duration of short circuit	[s]	1
Net Weight	kg	360
Width	mm	750
Depth	mm	1400
Height	mm	2250

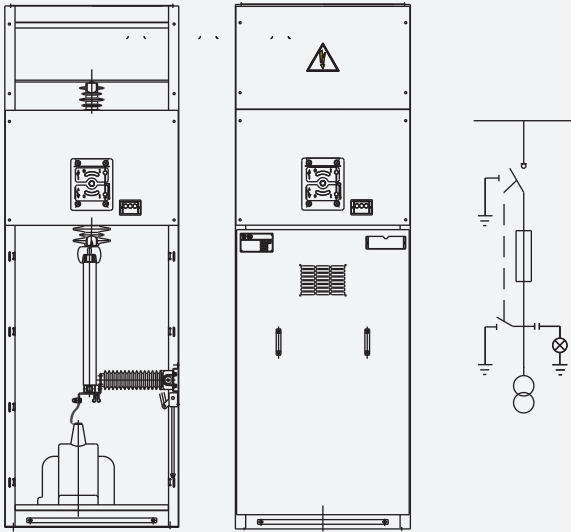

Standard equipment

1. 3 Position SF6 load break switch (open - closed - earthed)
2. Operating mechanism with mechanical position indication
3. Voltage transformers
4. Fuses
5. Voltage indicator device
6. Heater
7. Earthing bar
8. Busbars
9. Interlocking unit
10. Auxiliary contacts for close (2NO+2NC) and earth (2NO+2NC) position

Optional equipments

1. Earthing switch
2. Current transformers
3. Gas density indication
4. Gas density indication with alarm contact
5. Cable fault indication device
6. Arc-gas channel Metering

Technical data

Rated voltage	[kV]	36
Rated current	[A]	630/1250
Rated short-time withstand current	[kA]	20
Maximum rated duration of short circuit	[s]	1
Net Weight	kg	360
Width	mm	750
Depth	mm	1400
Height	mm	2250

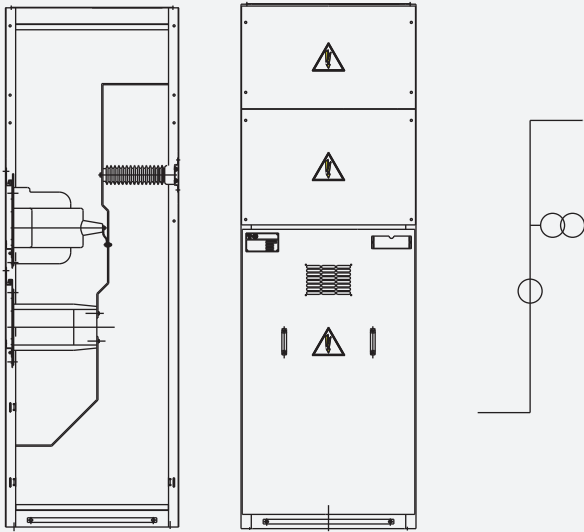

Standard equipment

1. Bushings
2. Current Transformers (toroidal or standard)
3. Voltage transformers
4. Busbars
5. Earthing bar
6. Ammeter ,Voltmeter
7. Heater
8. Interlocking unit
9. Voltage indicator device

Optional equipments

1. Energy meter
2. MV fuses
3. Surge arresters

Technical data

Rated voltage	[kV]	36
Rated current	[A]	630/1250
Rated short-time withstand current	[kA]	20
Maximum rated duration of short circuit	[s]	1
Net Weight	kg	180
Width	mm	750
Depth	mm	1400
Height	mm	2250

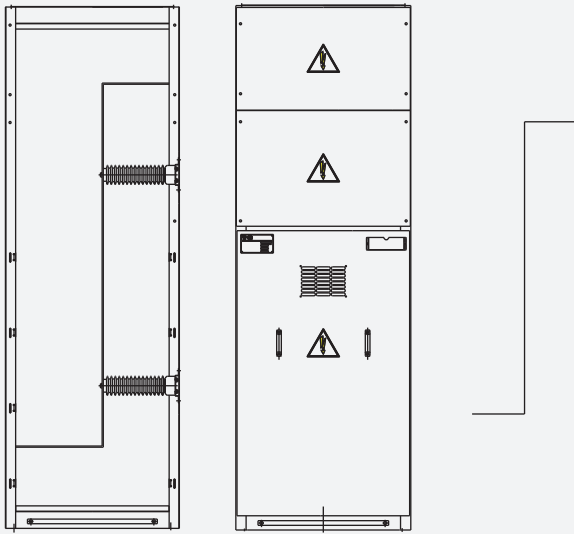

Standard equipment

1. Earthing switch
2. Voltage indicator device
3. Busbars
4. Earthing bar
5. Heater
6. Interlocking unit

Technical data

Rated voltage	[kV]	36
Rated current	[A]	630/1250
Rated short-time withstand current	[kA]	20
Maximum rated duration of short circuit	[s]	1
Net Weight	kg	125
Width	mm	700
Depth	mm	1400
Height	mm	2250

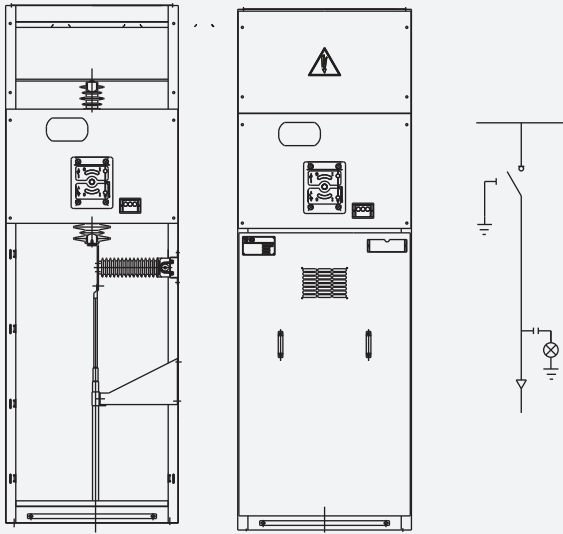

Standard equipment

1. 3 Position SF6 load break switch
(open - closed - earthed)
2. Operating mechanism with mechanical position indication
3. Voltage indicator device
4. Heater
5. Earthing bar
6. Busbars
7. Interlocking unit
8. Auxiliary contacts for close
(2NO+2NC) and earth (2NO+2NC) position
9. Cable entry with cable support

Optional equipments

1. Remote control with cable
(Opening and closing)
2. Remote control without cable
(Opening and closing)
3. Gas density indication
4. Gas density indication with alarm contact
5. Motor operation device
6. Cable fault indication device
7. Surge arresters
8. Current transformers
9. Arc-gas channel

Technical data

Rated voltage	[kV]	36
Rated current	[A]	630/1250
Rated short-time withstand current	[kA]	20
Maximum rated duration of short circuit	[s]	1
Net Weight	kg	240
Width	mm	750
Depth	mm	1400
Height	mm	2250

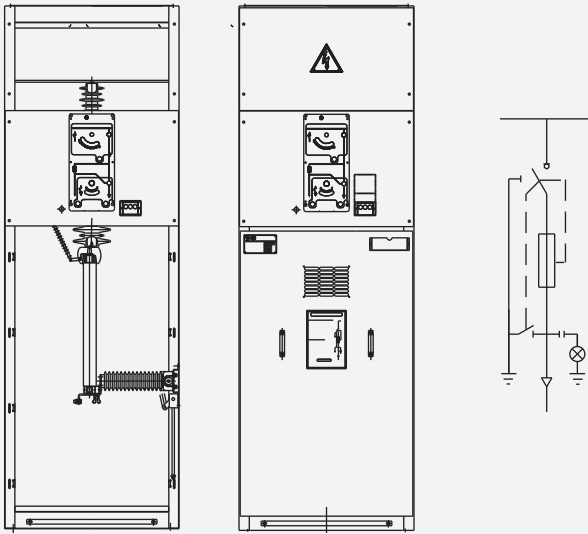

Standard equipment

1. 3 Position SF6 load break switch (open - closed - earthed)
2. Operating mechanism with mechanical position indication
3. Earthing switch 2 kA
4. Fuse
5. Voltage indicator device
6. Heater
7. Earthing bar
8. Busbars
9. Interlocking unit
10. Auxiliary contacts for close (2NO+2NC) and earth (2NO+2NC) position
11. Cable entry with cable support

Optional equipments

1. Remote control with cable (Opening and closing)
2. Remote control without cable (Opening and closing)³
3. Gas density indication
4. Gas density indication with alarm contact
5. Motor operation device
6. Cable fault indication device
7. Surge arresters
8. Current transformers
9. Arc-gas channel

Technical data

Rated voltage	[kV]	36
Rated current	[A]	630/1250
Rated short-time withstand current	[kA]	20
Maximum rated duration of short circuit	[s]	1
Net Weight	kg	275
Width	mm	750
Depth	mm	1400
Height	mm	2250

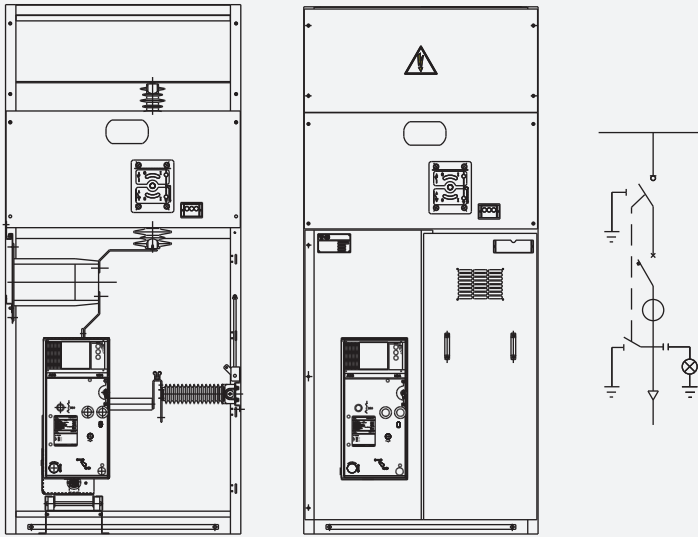

Standard equipment

1. 3 Position SF6 load break switch
(open - closed - earthed)
2. Operating mechanism with mechanical position indication
3. Circuit breaker, vacuum or SF6 type
4. Current transformers (toroidal or standard type)
5. Over current protection relay
6. Earthing switch 16 kA
7. Voltage indicator device
8. Heater
9. Earthing bar
10. Busbars
11. Interlocking unit
12. Auxiliary contacts for close
(2NO+2NC) and earth (2NO+2NC) position
13. Cable entry with cable support

Optional equipments

1. Remote control with cable
(Opening and closing)
2. Remote control without cable
(Opening and closing)
3. Gas density indication
4. Gas density indication with alarm contact
5. Motor operation device
6. Voltage transformers
7. Cable fault indication device
8. Arc-gas channel

Technical data

Rated voltage	[kV]	36
Rated current	[A]	630/1250
Rated short-time withstand current	[kA]	20
Maximum rated duration of short circuit	[s]	1
Net Weight	kg	420
Width	mm	1000
Depth	mm	1400
Height	mm	2250

Functioning concept

MS switches are made of an epoxy cast resin housing filled with SF6 gas at the pressure of 150 kPa abs., operative life sealed.

(Standard IEC 62271-103) The moving contact are fixed on the insulated rotary shaft inside the cast resin body, while the fixed contacts are mounted directly on the cast resin body.

The rotary motion of the shaft is made by an operating mechanism placed on the front. The switch has three different positions: closed, open and earthed, which naturally prevent any wrong operations.

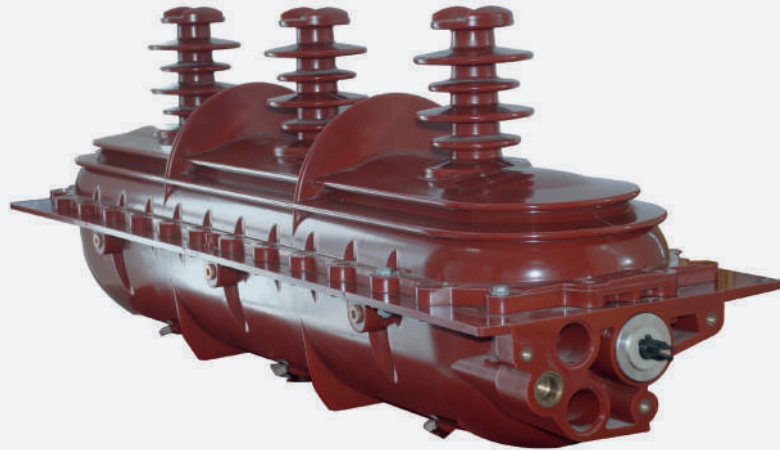

Characteristics

MS switches use sulphur hexafluoride gas (SF6) for insulation and breaking.

The active parts are placed in an insulating enclosure in accordance with the IEC standards for sealed pressure systems.

SF6 products offer remarkable characteristics:

Long service life - Maintenance-free active parts - Operating safety - Very low over-voltage level

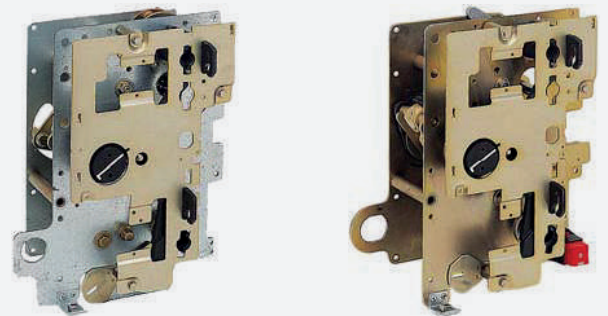

Technical Data	Load Break Switch MS	Earthing Switch
Rated voltage	36 kV	36 kV
Rated current	630 - 1250 A	
Rated short circuit withstand current	20 kA - 1 sec	20 kA - 1 sec
Electrical endurance	E2, E3	E1, E2
Mechanical endurance	M 1	M0
Applied standard	IEC 62271-103 1000 Operations	IEC 62271 - 102 1000 Operations

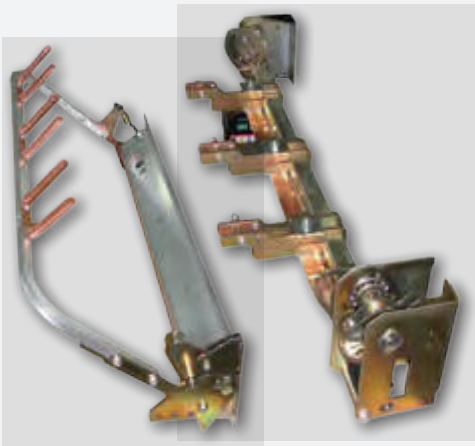

Earthing switch:

Rated voltage	36 kV	
Rated short circuit withstand	16 kA / 1 sn	20 kA / 1 sn
Current	1 kA / 1 sn*	
Standards applied	IEC 62271 - 103	

*Used at switch fuse combination cubicle at the downstream



Voltage transformers

The resin insulated voltage transformers are used for the feeding of measuring instruments and protection. They are suitable either for fixed installation or mounted on withdrawable trucks. They comply with IEC 60044 - 2 Standards. The dimensions of the fixed version comply with DIN standards 42600 Narrow Type. The withdrawable version equipped with fuses is custom made. The voltage transformers can be fitted either with one or two poles. Their performances and precision classes comply with the functional requirements of the apparatus they are connected to. The withdrawable version is equipped with medium voltage protection fuses, their replacement can be carried out while the switchboard is in service.



Current transformers

The current transformers are resin insulated and suitable for the feeding of measuring instruments and protections. These transformers can have a wound core or bushing bar with one or more cores. Their performances and precision classes comply with the apparatus requirements. The current transformers comply with IEC 60044 - 1 Standard. Their dimensions meet the requirements of DIN 42600 Standards. The current transformers can be equipped also with a capacitive socket for being connected to voltage indicator lamps.



Toroidal current transformers

The toroidal current transformers are resin insulated and suitable for the feeding of measuring instruments and protection. These transformers can have a ring or a split core. Their performances and precision classes comply with the apparatus requirements. They are suitable both for measuring phase currents and determining earth fault currents. They meet the requirements of IEC 60044 - 1 Standards.



Protection relay

MME Series switchboards can be equipped with different brand relay: THYTRONIC, SEB, MS, ABB, SIEMENS, SCHNEIDER or others.



3B ENERGY S.r.l.

REGISTERED OFFICE

Via Villani, 2 26900 LODI (LO) - Italy

Ph. +39 0371 1856259

Fax. +39 0371 9568847

www.3b-energy.com

info@3b-energy.com